

Pilot operated check, single manual shut-off

VSO-SE-DL-FCV-DX

05.52 - K - X - Y - Z

RE 18307-15

Edition: 09.2019

Replaces: 03.2016

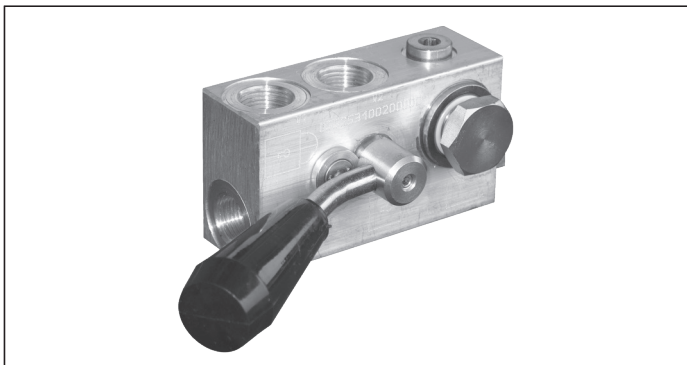

Technical data

Operating pressure	up to 210 bar (3000 psi)
Max. flow	30 l/min. (8 gpm)
Pilot ratio	5.4 : 1
Installation torque	50 - 55 Nm (37 - 41 ft-lbs)
Weight	0.6 kg (1.32 lbs)
Manifold material	Aluminium
Note: aluminium bodies are often strong enough for operating pressures exceeding 210 bar (3000 psi), depending from the fatigue life expected in the specific application. If in doubt, consult our Service Network.	
Fluid	Mineral oil (HL, HLP) according DIN 51524
Fluid temperature range	-30 °C to 100 (-22 to 212 °F)
Viscosity range	5 to 800 mm ² /s (cSt)
Recommended degree of fluid contamination	Class 19/17/14 according to ISO 4406
Other technical data	see data sheet 18350-50

Note: for applications outside these parameters, please consult us.

Description

A tap, manually controlled by the operator, allows inlet flow from V2 to pass through the check valve to C2: as a result, the motion of the actuator (typically the extension and positioning of an outrigger) happens under the operator's direct sight. The valve is normally closed (checked) and virtually leak-free from C2 to V2 in order to prevent reverse motion. Flow outlet from C2 to V2 and reverse motion (i.e. outrigger retraction or lifting up) is possible with manual tap open and if sufficient pilot pressure is present at V1-C1 so that the pilot piston may push the poppet from its seat. For compact assembly, the C2 port is banjo bolted directly onto the actuator port.

In case of valve application in redundancy systems it is especially recommended to use version with sealed pilot piston.

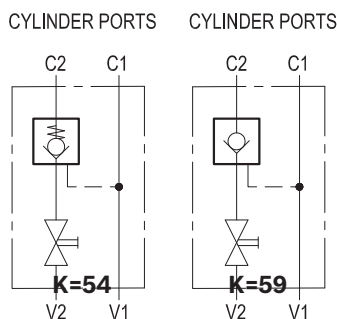

Characteristic curve

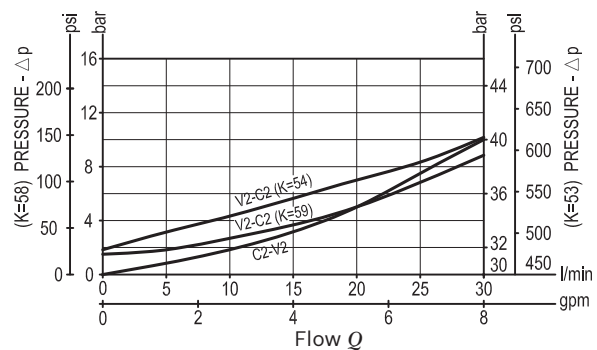

Ordering code

05.52	K	X	Y	Z
--------------	----------	----------	----------	----------

Pilot operated check, single manual shut-off

54
59 — see hydraulic schemes

O-Ring on pilot piston

10 With O-Ring

SPRINGS		
Cracking pressure bar (psi)		
00	for K=59	1.6 (23)
	for K=54	32 (464)

Port sizes	V1 - V2	C1 - C2
02	G 3/8	G 3/8

Preferred types

Type	Material number
055254100200000	R930002365
055259100200000	R930002368

Type	Material number

Dimensions

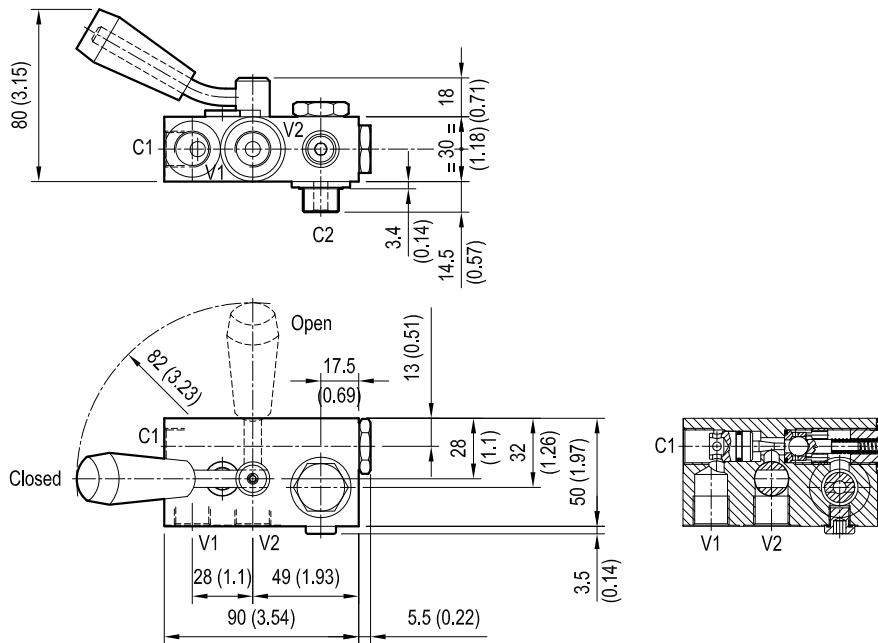

Bosch Rexroth Oil Control S.p.A.

Via Leonardo da Vinci 5
 P.O. Box no. 5
 41015 Nonantola – Modena, Italy
 Tel. +39 059 887 611
 Fax +39 059 547 848
 compact-hydraulics-pib@boschrexroth.com
 www.boschrexroth.com/compacthydraulics

© This document, as well as the data, specifications and other information set forth in it, are the exclusive property of Bosch Rexroth Oil Control S.p.a.. It may not be reproduced or given to third parties without its consent. The data specified above only serve to describe the product. No statements concerning a certain condition or suitability for a certain application can be derived from our information. The information given does not release the user from the obligation of own judgment and verification. It must be remembered that our products are subject to a natural process of wear and aging. Subject to change.