

Single counterbalance with brake release port for winches flangeable to motor

VBSO-SE-FA-RD-90

05.35.01 - X - Y - Z

RE 18308-41

Edition: 03.2016

Replaces: 04.2010

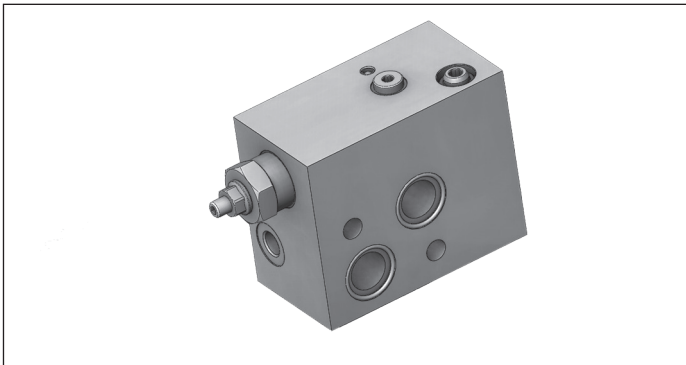

Description

When pressure at V2 rises above the spring bias pressure, the check seat is pushed away from the piston and flow is allowed from V2 to C2. When load pressure at C2 rises above the pressure setting, the direct operated relief function is activated and flow is relieved from C2 to V2. With pilot pressure at C5, the pressure setting is reduced in proportion to the stated ratio of the valve, until opening and allowing flow from C2 to V2. The spring chamber is drained to V2, and any back-pressure at V2 is additive to the pressure setting in all functions. Through port C3, an incorporated shuttle valve directs either V1 or V2 line pressure to the spring actuated brake for brake opening. Through port D, a twin check valve system recovers any oil drain from the motor and delivers it to either V1 or V2 line, depending on which one is open to tank.

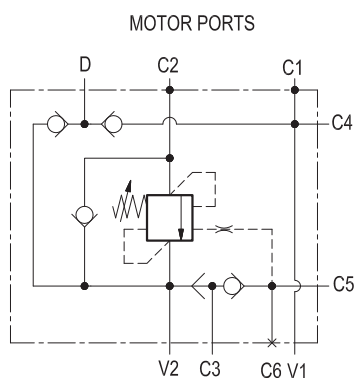

Technical data

Operating pressure	up to 210 bar (3000 psi)
Max. flow	90 l/min. (24 gpm)
Flangeable on SAUER-DANFOSS orbital motors OMS-OMSW-OMSS series.	
Relief setting: at least 1.3 times the highest expected load. In addition, both the relief setting and the pilot ratio must be determined also in order to achieve building-up of pilot pressure in V1 high enough to release the brake prior to any valve opening from C2 to V2.	
Weight	1.6 kg (3.5 lbs)
Manifold material	Anodized aluminium

Note: aluminium bodies are often strong enough for operating pressures exceeding 210 bar (3000 psi), depending from the fatigue life expected in the specific application. If in doubt, consult our Service Network.

Flange seal kit ¹⁾	E00000000000032 (R930005697)
Fluid	Mineral oil (HL, HLP) according DIN 51524
Fluid temperature range	-30 °C to 100 (-22 to 212 °F)
Viscosity range	10 to 500 mm ² /s (cSt)
Recommended degree of fluid contamination	Class 19/17/14 according to ISO 4406
Other technical data	see data sheet 18350-50

Note: for applications outside these parameters, please consult us.

¹⁾ Seals for 10 valves

Characteristic curve

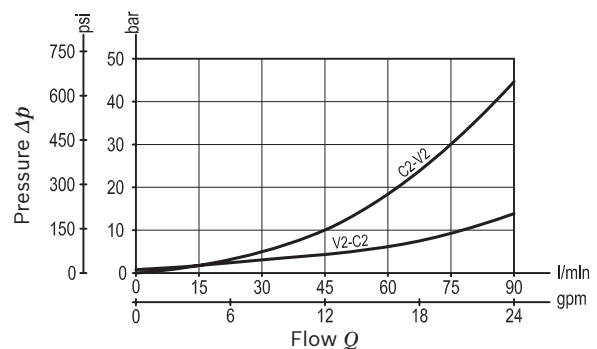

Ordering code

05.35.01	X	Y	Z
-----------------	----------	----------	----------

Single counterbalance,
with brake release port for winches
flangeable to motor

Pilot ratio

03 4.2:1

SPRINGS		
Adj. pressure range bar (psi)	Pres. increase bar/turn (psi/turn)	Std. setting Q=5 (l/min) bar (psi)
35 150-350 (2175-5000)	120 (1740)	350 (5000)

Tamper resistant cap
ordering code 11.04.23.002
Mat. no. R930000752



Port sizes	V1-V2	C1-C2	C3-C4-C5-D	C6
03	G 1/2	∅ 19 (0.75)	G 1/4	G 1/4

Preferred types

Type	Material number
053501030335000	R930001513

Type	Material number

Dimensions

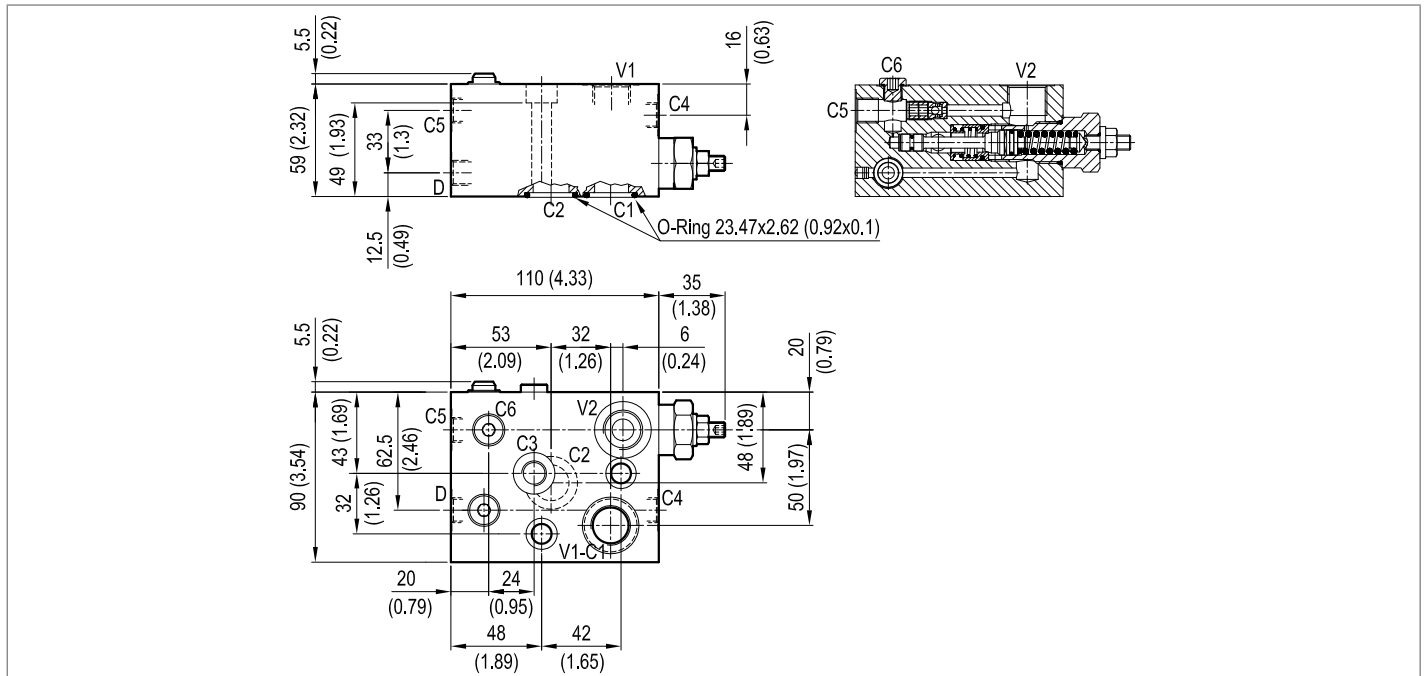

Bosch Rexroth Oil Control S.p.A.

Via Leonardo da Vinci 5
P.O. Box no. 5
41015 Nonantola – Modena, Italy
Tel. +39 059 887 611
Fax +39 059 547 848
compact-hydraulics-pib@boschrexroth.com
www.boschrexroth.com/compacthydraulics

© This document, as well as the data, specifications and other information set forth in it, are the exclusive property of Bosch Rexroth Oil Control S.p.a.. It may not be reproduced or given to third parties without its consent. The data specified above only serve to describe the product. No statements concerning a certain condition or suitability for a certain application can be derived from our information. The information given does not release the user from the obligation of own judgment and verification. It must be remembered that our products are subject to a natural process of wear and aging. Subject to change.