

Check and metering valve flangeable

A-VBCN-18-FC

08.37.18.18 - Y - Z

RE 18309-14

Edition: 03.2016

Replaces: 07.2012

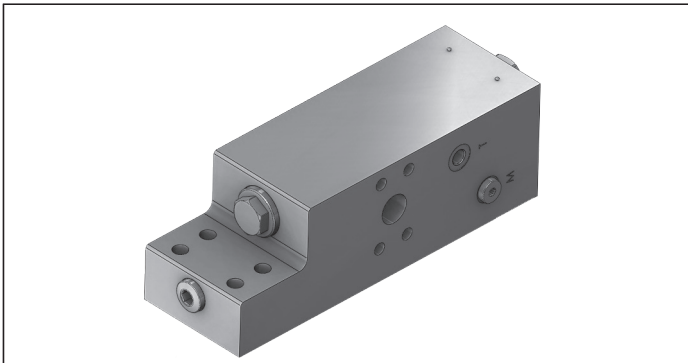

Technical data

Max. operating pressure	420 bar (6000 psi)
Max. flow	300 /min. (79 gpm)
Weight	19 kg (42 lbs)
Flange seal kit ¹⁾	E00000000000003 (R930004533)
Manifold material	Zinc plated steel
Fluid	Mineral oil (HL, HLP) according DIN 51524
Fluid temperature range	-30 °C to 100 (-22 to 212 °F)
Viscosity range	10 to 500 mm ² /s (cSt)
Recommended degree of fluid contamination	Class 19/17/14 according to ISO 4406
The Tank vented port must be connected to a "low pressure tank line" (to the joystick tank line, or to tank directly).	
The restricted "M" port must be connected to a "pressure equalizing line" in case of 2 valves fitted to 2 twin cylinders, and may be used as "outlet to tank" for emergency boom lowering in case of pilot pressure failure.	
This valve with specific adjustments, it can become part of load holding and load lowering systems designed to comply with ISO Standard 8643 (hose burst protection).	
Other technical data	see data sheet 18350-50

Note: for applications outside these parameters, please consult us.

¹⁾ Seals for 10 valves.

Description

Unrestricted upstream flow (A – A1) to the cylinder is possible through the check valve (1), while downstream flow (A1 – A) is locked by the leak free main spool (2) which is held closed by the spring and by the load induced pressure. With pilot pressure at X (joystick), the spool (2) is first vented to tank then it is remotely controlled and it slides to provide metering for the downstream flow; after the initial venting, the pilot pressure required to move the spool is load independent. The downstream (A1 – A) metering curve and the cracking pressure are factory designed and set for the specific type of machine and cannot be adjusted. The valve includes a small relief cartridge (3) which senses the A1 pressure (load induced) and opens under overload or shock conditions in order to pilot fully open the main spool (2): this allows any excess of pressure at A1 to be relieved downstream through A. For better safety and compact assembly, the A1 port is gasket mounted directly on the actuator.

Note: port identified with M are not protected with calibrated orifice but in direct connection with pressure channels.

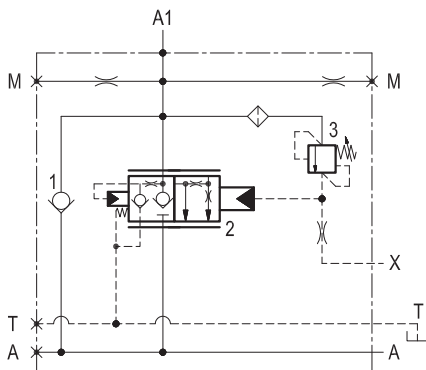

Characteristic curve

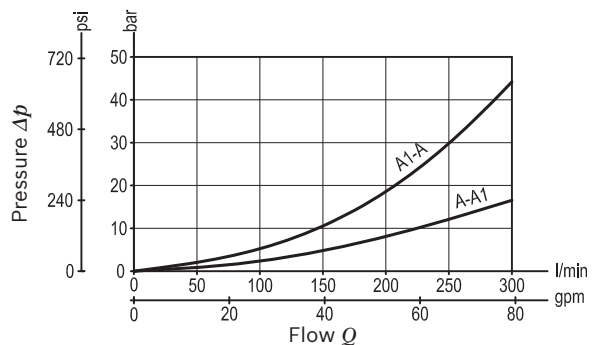

Ordering code

08.37.18	18	Y	Z
-----------------	-----------	----------	----------

Check and metering valve
flangeable

18 Spool type

Port sizes A - A1 M-T-X

73 1 SAE 6000 G 1/4

SPRINGS

		Adj. pressure range bar (psi)	Pres. increase bar/turn (psi/turn)	Std. setting bar (psi)
46	Valve 2			7.5 (109) "cracking"
	Valve 3	350-460 (5000-6700)	228 (3306)	350 (5000) "5 l/min"

Tamper resistant cap
ordering code 11.04.31.001
Mat. no. R930000777
for Valve 3



Preferred types

Type	Material number
083718187346000	R930003755

Type	Material number

Dimensions

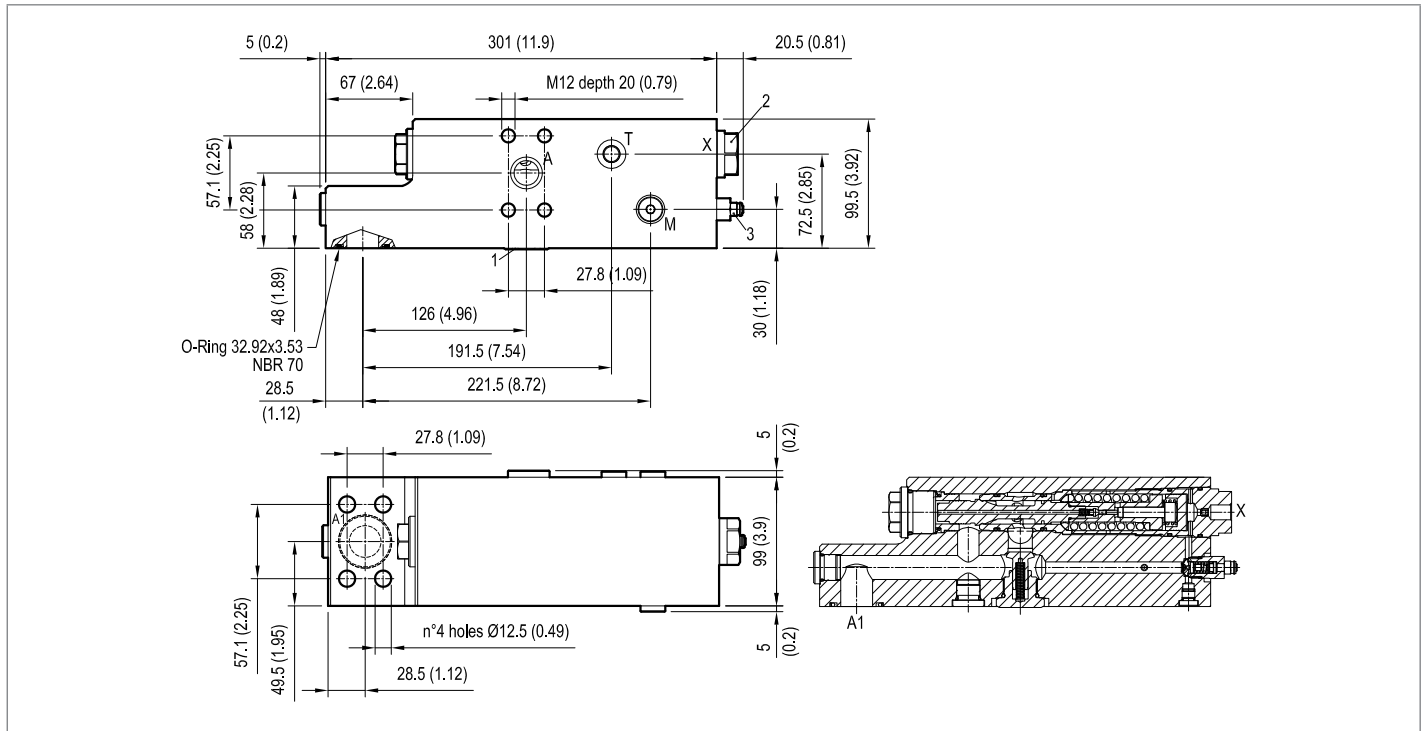

Bosch Rexroth Oil Control S.p.A.

Via Leonardo da Vinci 5
P.O. Box no. 5
41015 Nonantola - Modena, Italy
Tel. +39 059 887 611
Fax +39 059 547 848
compact-hydraulics-pib@boschrexroth.com
www.boschrexroth.com/compacthydraulics

© This document, as well as the data, specifications and other information set forth in it, are the exclusive property of Bosch Rexroth Oil Control S.p.a.. It may not be reproduced or given to third parties without its consent. The data specified above only serve to describe the product. No statements concerning a certain condition or suitability for a certain application can be derived from our information. The information given does not release the user from the obligation of own judgment and verification. It must be remembered that our products are subject to a natural process of wear and aging. Subject to change.